



# PARTICLE COUNTERS

## General Catalog

2025



# PARTICLE COUNTERS

## Basic particle counter principles

### The theory of light scattering

When particle size becomes smaller than the wavelength of light, the scattering of light energy by particles plays a more dominant role than reflection or refraction.

The intensity of the scattered light has a constant relationship to particle size, the refractive index of particles and medium, light wavelength, etc., and it is possible to determine the size of the particle by measuring the intensity of scattered light.

Interaction between light and particles

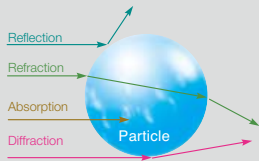

Wavelength, particle refractive index and medium refractive index are constant

The intensity of scattered light is dependent on particle size

### Light-scattering method

Light scattering occurs when the sample introduced through the inlet nozzle is irradiated with light and then the particles pass through the light. The scattered light is detected by the photo detector and is converted to electrical signals.

The size of the electrical signals represents the particle size and the frequency of scattered-light detection represents the particle count. A particle detection cell (flow cell) made of fused silica or sapphire is used if the sample is liquid.

### Outline drawing of the light-scattering method sensor

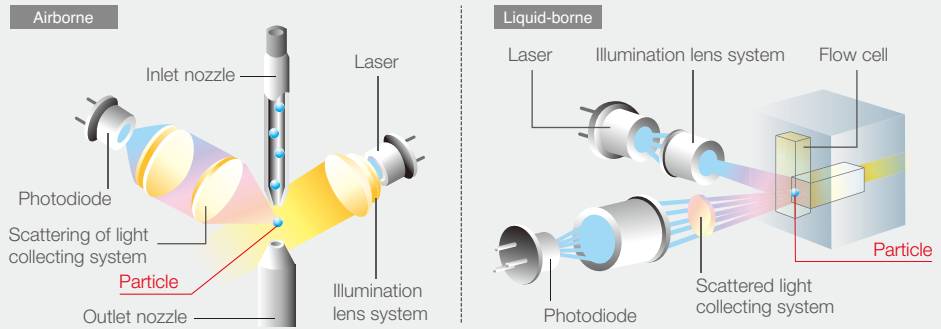

### Internal flow diagram

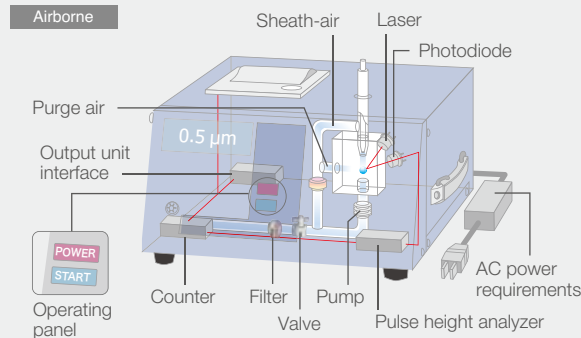

### Relationship between particle signals, particle size and number of particle

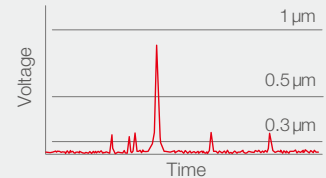

No. of particles 0.3µm and above : 6  
No. of particles 0.5µm and above : 1  
No. of particles 1µm and above : 0

## INDEX

- 2 Basic particle counter principle / index
- 3 Overview of airborne particle counters
- 4 ISO / Examples of airborne particle counter measurement
- 5 Airborne particle counters
- 9 Overview of liquid-borne particle counters
- 10 ISO / Examples of liquid-borne particle counter measurement
- 11 Examples of liquid-borne particle counter systems
- 12 Liquid-borne particle counters
- 17 Overview of gas-borne particle counters / KS-93
- 18 Example of multi-point monitoring system installation (Sensors, Tubes)
- 19 Software / Multi-point monitoring software
- 20 Overview of pharmaceuticals / pharmaceutical standards / KL-05 / Injection fluid measurement systems
- 21 Validation
- 22 Options
- 23 Company outline

### Light obscuration method

The light source irradiating photo detector, light is converted to electrical signals. Light detected by the photo detector becomes smaller when particles pass through the light. The attenuated amount of the electrical signals represents the particle size and the frequency of light blocking represents the particle count.

### Outline drawing of light obscuration method sensor

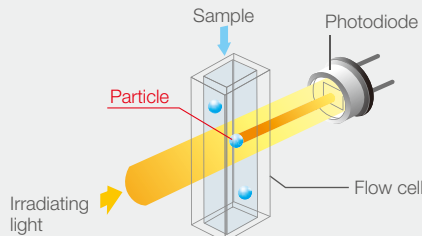

### Results of polystyrene latex particle pulse height analysis

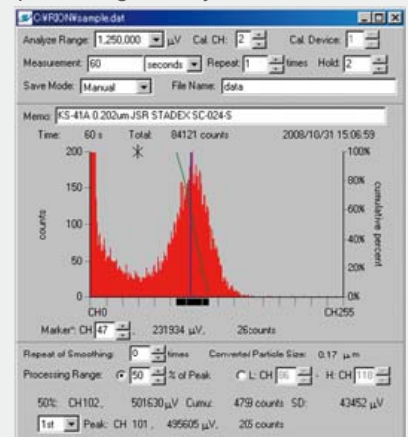



# PARTICLE COUNTERS AIR BORNE

## Clean Environments require High accuracy monitoring solutions

Demands for the further miniaturization and refinement of products are becoming increasingly stronger in this age of nanotechnology. Research into microorganisms, dust and other contaminants that have an effect on the human body is also being pursued vigorously.

## Major fields of use of airborne particle counters

Airborne particle counters are used for the purpose of counting the number of particles suspended in the air including airborne particle management and filter performance tests in cleanrooms, air showers, mini-environments (front opening unified pod (FOUP), etc.), and dust generation tests for hard disc drive (HDD) parts, etc. Cleanrooms consist of industrial clean rooms (ICR), used in semiconductor and flat panel display (FPD) production and in other industrial fields, and biological clean rooms

(BCR) used in pharmaceutical and food production, hospitals and surgery rooms and managed particle size differs in each industrial field.

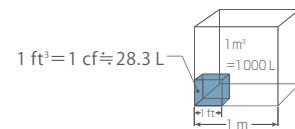

## Cleanliness classes

Cleanliness class is determined by ISO 14644-1. Maximum concentration for each cleanliness class and its measured particle size is defined as shown in the Tabl.1. The expressions of "class 100" and "class 10 000," which have been used for many years, originate from the U.S. standards Fed-Std-209E where cleanrooms with a maximum of 100 particles of 0.5 μm or larger per cubic foot (Approx. 28.3 L) were considered to be class 100. This standard, however, was eliminated in November 2001 prompted by the formulation of the ISO standards. The Fed-Std-209E classes that correspond to the ISO cleanliness classes are indicated on the right-hand side of Table 1. Cleanrooms are also used and managed for the purpose of preventing foreign matter

from mixing, contamination and infection in biotechnology, medical treatment, pharmaceutical production, and food product industries. Besides the management of maximum concentration based on particle count, controlling microorganisms has also become necessary in cleanroom management. The concentration of suspended bacteria is regulated by PIC/S, GMP, JP, FDA and so forth while the maximum concentration of particles draws upon ISO 14644-1 and other standards.

Determining the maximum concentration for each particle size

$$\text{Max. concentration } C_n = 10^{\frac{\text{class no.}}{N}} \times \left( \frac{0.1}{\text{diameter } D} \right)^{2.08}$$

Table 1 Maximum concentration by cleanliness class and measured particle size

Cleanliness class N	Max. concentration (no./m³)						Fed-Std-209E
	Measured particle size						
	0.1 μm	0.2 μm	0.3 μm	0.5 μm	1 μm	5 μm	
Class 1	10						
Class 2	100		10				
Class 3	1 000	24	102	35			1
Class 4	10 000	2 370	1 020	352	83		10
Class 5	100 000	23 700	10 200	3 520	832		100
Class 6	1 000 000	237 000	102 000	35 200	8 320	293	1 000
Class 7				352 000	83 200	2 930	10 000
Class 8				3 520 000	832 000	29 300	100 000
Class 9				35 200 000	8 320 000	293 000	

Table 2 Evaluation method for cleanroom

Item	Normal evaluation method	Sequential sampling air cleanliness evaluation method
Space targeted for measurement	Cleanrooms or spaces with controlled particle environment	
Particle size targeted for measurement	Diameter of 1 or multiple particles within the range of 0.1 to 5 μm	
Cleanliness class indication	As shown in Table.1.	
Evaluation method	Measured concentration for each point should not exceed the upper limit for cleanliness class.	The measurement points are judged to comply with the cleanliness class as long as they are in the conformity region of the sequential sampling air cleanliness evaluation conformity diagram.
Cleanliness class subject to evaluation	Cleanliness classes 1 to 9	Cleanliness classes 1 to 4
Measurement equipment	Light scattering air borne particle counter	
Sampling capacity	The maximum particle count of the cleanliness class subject to evaluation is a capacity of 20 particles, a measurement time of 1 min., or a capacity of 2 L, whichever is larger.	
Sampling location	The sampling location in principle is the height of the workbench	

Table 3 Number of measurement point

Area of cleanroom (m²) less than or equal to	Minimum number of sample locations to be tested (N <sub>L</sub> )	Area of cleanroom (m²) less than or equal to	Minimum number of sample locations to be tested (N <sub>L</sub> )	Area of cleanroom (m²) less than or equal to	Minimum number of sample locations to be tested (N <sub>L</sub> )
2	1	52	10	148	19
4	2	56	11	156	20
6	3	64	12	192	21
8	4	68	13	232	22
10	5	72	14	276	23
24	6	76	15	352	24
28	7	104	16	436	25
32	8	108	17	636	26
36	9	116	18	1 000	27

When A is more than 1 000 m²,  $N_L = 27 \times \frac{A}{1000}$

### Major change in ISO 14644-1: 2015

- Maximum concentration to determine the cleanliness level has been changed from "average from all measured points" to "individual points must not exceed upper limit".
- Number of points to measure is selected based on Table.3.
- Concentration of 5μm at class 5 has been deleted.
- Determination standard of 95% upper confidence limits for measurement points 2 to 9 has been deleted.
- The specification of the number of measurement times has been removed.
- Calibration cycles based on ISO 21501-4 have been added.

PARTICLE COUNTERS AIRBORNE  
PARTICLE COUNTERS LIQUID-BORNE  
PARTICLE COUNTERS GAS-BORNE  
PARTICLE COUNTERS MONITORING SYSTEM  
PARTICLE COUNTERS PHARMACEUTICAL PRODUCTS  
PARTICLE COUNTERS VALIDATION  
PARTICLE COUNTERS OPTION  
COMPANY OUTLINE

## Air cleanliness in sterile pharmaceutical production areas

PIC/S-GMP Cleanroom classification

Grade	Maximum limits for total particle $\geq 0.5 \mu\text{m}/\text{m}^3$		Maximum limits for total particle $\geq 5 \mu\text{m}/\text{m}^3$	
	at rest	in operation	at rest	in operation
A	3 520	3 520	.....	.....
B	3 520	352 000	.....	2 930
C	352 000	3 520 000	2 930	29 300
D	3 520 000	.....	29 300	.....

PIC/S-GMP Environmental monitoring

Grade	Maximum limits for total particle $\geq 0.5 \mu\text{m}/\text{m}^3$		Maximum limits for total particle $\geq 5 \mu\text{m}/\text{m}^3$	
	at rest	in operation	at rest	in operation
A	3 520	3 520	29	29
B	3 520	352 000	29	2 930
C	352 000	3 520 000	2 930	29 300
D	3 520 000	.....	29 300	.....

FDA (Food and Drug Administration)

Cleanliness area class	Maximum permitted particle count $\text{N}/\text{m}^3$	
	$0.5 \mu\text{m}$	Airborne suspended bacteria $\text{cfu}/\text{m}^3$
100	3 520	<1
	1 000	7
	10 000	10
	100 000	100

Relationship between airborne suspended bacteria and suspended particles NASA NHB 5340.2

Cleanliness area class	Airborne suspended bacteria ( $\text{cfu}/\text{m}^3$ )	Settle plates ( $\text{cfu}/\text{m}^2/\text{week}$ )
100	3.5	12 900
10 000	18	64 600
100 000	88	323 000

### Standards for particle counters

#### [Light scattering airborne particle counter for clean spaces] (An extract)

##### ISO 21501-4

##### Counting efficiency

The counting efficiency shall be  $(50 \pm 20) \%$  for calibration particles with a size close to the minimum detectable size, and it shall be  $(100 \pm 10) \%$  for calibration particles with a size of 1,5 times to 2 times larger than the minimum detectable particle size.

##### False count rate

The false count rate is determined by measuring the particle number concentration in the unit of counts per cubic meter at the minimum reported size range when sampling clean air.

##### Sampling flow rate

The standard uncertainty of volumetric flow rate shall be equal to or less than  $\pm 5 \%$ .

##### Maximum particle number concentration

The maximum measurable particle number concentration shall be specified by the manufacturer.

The coincidence loss at the maximum particle number concentration of an LSAPC shall be equal to or less than 10 %.

NOTE When the particle number concentration is higher than the maximum particle number concentration, the number of uncounted particles increases because of an enhanced probability of multiple particles existing in the sensing volume (coincidence error) and/or saturation of the electronic system.

##### Calibration interval

It is recommended that the calibration interval of an LSAPC be one year or less.

## Examples of airborne particle measurement

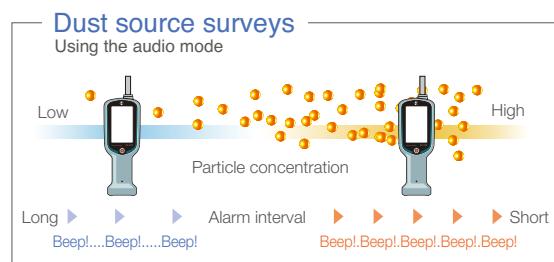
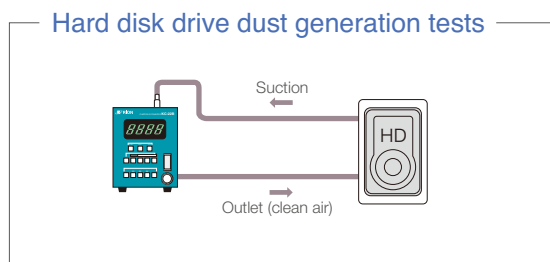
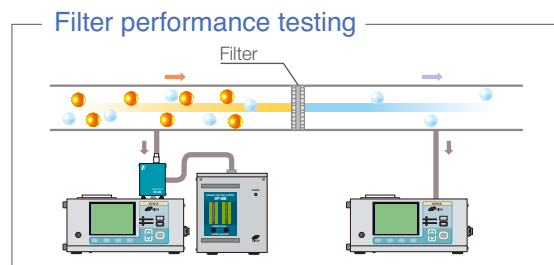
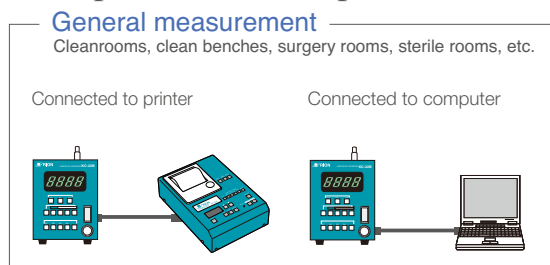



Not available in EU.

## Particle Counter KC-22A (Light-scattering method)

Light source	Diode pumped solid state laser (wavelength 1 064 nm)
Flow rate	2.83 L/min
Size range (5 channels)	$\geq 0.1 \mu\text{m}$ , $\geq 0.15 \mu\text{m}$ , $\geq 0.2 \mu\text{m}$ , $\geq 0.3 \mu\text{m}$ , $\geq 0.5 \mu\text{m}$
Maximum particle number concentration	10 000 particles/L (coincidence loss 5 %)
Sampling tube diameter	Outside diameter: $\phi 7$ mm, Inside diameter: $\phi 5$ mm
Power	100 V AC, 50/60 Hz, Approx. 80 VA
Dimensions and weight	Approx. 185 (H) $\times$ 155 (W) $\times$ 330 (D) mm, Approx. 7.5 kg



Not available in EU.

## Particle Counter KC-22B (Light-scattering method)

Light source	Diode pumped solid state laser (wavelength 1 064 nm)
Flow rate	0.3 L/min
Size range (5 channels)	$\geq 0.08 \mu\text{m}$ , $\geq 0.1 \mu\text{m}$ , $\geq 0.2 \mu\text{m}$ , $\geq 0.3 \mu\text{m}$ , $\geq 0.5 \mu\text{m}$
Maximum particle number concentration	100 000 particles/L (coincidence loss 5 %)
Sampling tube diameter	Outside diameter: $\phi 7$ mm, Inside diameter: $\phi 5$ mm
Power	100 V to 240 V AC, 50/60 Hz, Approx. 90 VA
Dimensions and weight	Approx. 185 (H) $\times$ 155 (W) $\times$ 330 (D) mm, Approx. 7 kg



Not available in EU.

## Particle Counter KC-24 (Light-scattering method)

Light source	Diode pumped solid state laser (wavelength 1 064 nm)
Flow rate	28.3 L/min
Size range (5 channels)	$\geq 0.1 \mu\text{m}$ , $\geq 0.15 \mu\text{m}$ , $\geq 0.2 \mu\text{m}$ , $\geq 0.3 \mu\text{m}$ , $\geq 0.5 \mu\text{m}$
Maximum particle number concentration	2 000 000 particles/m <sup>3</sup> (coincidence loss 10 %)
Sampling tube diameter	Outside diameter: $\phi 11$ mm, Inside diameter: $\phi 7$ mm
Power	100 V to 240 V AC, 50/60 Hz, Approx. 300 VA
Dimensions and weight	Approx. 280 (H) $\times$ 320 (W) $\times$ 450 (D) mm, Approx. 19.4 kg

# PARTICLE COUNTERS AIR BORNE



## Particle Counter KC-31 (Light-scattering method)

Light source	Laser diode (wavelength 780 nm, rated output 100 mW)
Flow rate	28.3 L/min
Size range (6 channels)	$\geq 0.3 \mu\text{m}$ , $\geq 0.5 \mu\text{m}$ , $\geq 1.0 \mu\text{m}$ , $\geq 2.0 \mu\text{m}$ , $\geq 5.0 \mu\text{m}$ , $\geq 10.0 \mu\text{m}$
Maximum particle number concentration	28 000 000 particles/m <sup>3</sup> (coincidence loss 10 %)
Sampling tube diameter	Outside diameter: $\phi$ 16 mm, Inside diameter: $\phi$ 12 mm
Power	Lithium ion battery or AC adapter (100 V to 240 V AC, 50/60 Hz)
Dimensions and weight	Approx. 203 (H) $\times$ 260 (W) $\times$ 266 (D) mm (excl. protruding parts), Approx. 5.5 kg (with 1 battery)



## Particle Counter KC-32 (Light-scattering method)

Light source	Laser diode (wavelength 780 nm, rated output 100 mW)
Flow rate	50 L/min
Size range (6 channels)	$\geq 0.3 \mu\text{m}$ , $\geq 0.5 \mu\text{m}$ , $\geq 1.0 \mu\text{m}$ , $\geq 2.0 \mu\text{m}$ , $\geq 5.0 \mu\text{m}$ , $\geq 10.0 \mu\text{m}$
Maximum particle number concentration	16 000 000 particles/m <sup>3</sup> (coincidence loss 10 %)
Sampling tube diameter	Outside diameter: $\phi$ 16 mm, Inside diameter: $\phi$ 12 mm
Power	Lithium ion battery or AC adapter (100 V to 240 V AC, 50/60 Hz)
Dimensions and weight	Approx. 203 (H) $\times$ 260 (W) $\times$ 266 (D) mm (excl. protruding parts), Approx. 5.5 kg (with 1 battery)



## Particle Counter KC-20A (Light-scattering method)

Light source	Laser diode (wavelength 780 nm, rated output 3 mW)
Flow rate	30 L/min
Size range (5 channels)	$\geq 10 \mu\text{m}$ , $\geq 20 \mu\text{m}$ , $\geq 30 \mu\text{m}$ , $\geq 50 \mu\text{m}$ , $\geq 100 \mu\text{m}$
Maximum particle number concentration	2 000 particles/L (coincidence loss 5 %)
Sampling tube diameter	Outside diameter: $\phi$ 11 mm, Inside diameter: $\phi$ 7 mm
Power	100 V to 240 V AC, 50/60 Hz, Approx. 160 VA
Dimensions and weight	Approx. 135 (H) $\times$ 300 (W) $\times$ 401 (D) mm, Approx. 11.6 kg



## Hand-held Particle Counter KC-51 (Light-scattering method)

Light source	Laser diode (wavelength 780 nm, rated output 35 mW)
Flow rate	2.83 L/min
Size range	3 channels: 0.3 µm, 0.5 µm, 5 µm (Default setting) (User selectable channels) 2 channels: 0.3 µm, 0.5 µm 2 channels: 0.5 µm, 5.0 µm
Maximum particle number concentration	140 000 000 particles/m <sup>3</sup> (coincidence loss 10 %)
Sampling tube diameter	Outside diameter: φ 8 mm, Inside diameter: φ 6 mm
Power	Built-in battery or AC adapter (100 V to 240 V AC, 50/60 Hz)
Dimensions and weight	Approx. 304 (H) × 87 (W) × 55 (D) mm, Approx. 780 g



## Hand-held Particle Counter KC-52A (Light-scattering method)

Light source	Laser diode (wavelength 780 nm, rated output 35 mW)
Flow rate	2.83 L/min
Size range (6 channels)	≥ 0.3 µm, ≥ 0.5 µm, ≥ 1.0 µm, ≥ 2.0 µm, ≥ 5.0 µm, ≥ 10.0 µm
Maximum particle number concentration	140 000 000 particles/m <sup>3</sup> (coincidence loss 10 %)
Sampling tube diameter	Outside diameter: φ 8 mm, Inside diameter: φ 6 mm
Power	Built-in battery or AC adapter (100 V to 240 V AC, 50/60 Hz)
Dimensions and weight	Approx. 307 (H) × 93 (W) × 54 (D) mm, Approx. 680 g



## Particle Counter KC-01E (Light-scattering method)

Light source	Laser diode (wavelength 780 nm, rated output 40 mW)
Flow rate	0.5 L/min
Size range (5 channels)	≥ 0.3 µm, ≥ 0.5 µm, ≥ 1 µm, ≥ 2 µm, ≥ 5 µm
Maximum particle number concentration	100 000 particles/L (coincidence loss 5 %)
Sampling tube diameter	Outside diameter: φ 7 mm, Inside diameter: φ 5 mm
Power	100 V to 240 V AC, 50/60 Hz, Approx. 50 VA
Dimensions and weight	Approx. 135 (H) × 300 (W) × 300 (D) mm, Approx. 6.3 kg



## Particle Counter KC-03B (Light-scattering method)

Light source	Laser diode (wavelength 780 nm, rated output 40 mW)
Flow rate	3 L/min
Size range (5 channels)	≥ 0.3 µm, ≥ 0.5 µm, ≥ 1 µm, ≥ 2 µm, ≥ 5 µm
Maximum particle number concentration	30 000 particles/L (coincidence loss 5 %)
Sampling tube diameter	Outside diameter: φ 7 mm, Inside diameter: φ 5 mm
Power	100 V to 240 V AC, 50/60 Hz, Approx. 65 VA
Dimensions and weight	Approx. 135 (H) × 300 (W) × 300 (D) mm, Approx. 7.3 kg

# PARTICLE COUNTERS AIR BORNE



## Particle Sensor KA-05 (Light-scattering method)

Light source	Laser diode (wavelength 785 nm, rated output 70 mW)
Flow rate	28.3 L/min
Size range (2 channels)	$\geq 0.5 \mu\text{m}$ , $\geq 5.0 \mu\text{m}$
Maximum particle number concentration	28 000 000 particles/m <sup>3</sup> (coincidence loss 10 %)
Sampling tube diameter	Inside diameter: $\phi$ 6 mm
Power	9 to 28 V DC (supplied by external unit, option)
Dimensions and weight	Approx. 90 (H) x 130 (W) x 58 (D) mm (excl. protruding parts), Approx. 2 kg



## Particle Sensor KA-02 (Light-scattering method)

Light source	Laser diode (wavelength 780 nm, rated output 35 mW)
Flow rate	2.83 L/min
Size range (2 channels)	$\geq 0.3 \mu\text{m}$ , $\geq 0.5 \mu\text{m}$
Maximum particle number concentration	140 000 000 particles/m <sup>3</sup> (coincidence loss 10 %)
Sampling tube diameter	Internal diameter: 1/8-inch, (approx. 3.2 mm)
Power	9 to 28 V DC (supplied by external unit, option)
Dimensions and weight	Approx. 52 (H) x 107 (W) x 53 (D) mm (excl. protruding parts), Approx. 360 g



## Particle Sensor KA-03 (Light-scattering method)

Light source	Laser diode (wavelength 780 nm, rated output 35 mW)
Flow rate	2.83 L/min
Size range (5 channels)	$\geq 0.3 \mu\text{m}$ , $\geq 0.5 \mu\text{m}$ , $\geq 1.0 \mu\text{m}$ , $\geq 2.0 \mu\text{m}$ , $\geq 5.0 \mu\text{m}$
Maximum particle number concentration	140 000 000 particles/m <sup>3</sup> (coincidence loss 10 %)
Sampling tube diameter	Outside diameter: $\phi$ 7 mm, Inside diameter: $\phi$ 5 mm
Power	AC adapter (100 V to 240 V AC, 50/60 Hz)
Dimensions and weight	Approx. 126 (H) x 87 (W) x 204 (D) mm (excl. protruding parts), Approx. 2 kg



## Particle Sensor KA-82 (Light-scattering method)

Light source	Diode pumped solid state laser (wavelength 1 064 nm)
Flow rate	2.83 L/min
Size range (5 channels)	$\geq 0.1 \mu\text{m}$ , $\geq 0.15 \mu\text{m}$ , $\geq 0.2 \mu\text{m}$ , $\geq 0.3 \mu\text{m}$ , $\geq 0.5 \mu\text{m}$
Maximum particle number concentration	10 000 particles/L (coincidence loss 5 %)
Sampling tube diameter	Outside diameter: $\phi$ 7 mm, Inside diameter: $\phi$ 5 mm
Power	100 V to 240 V AC, 50/60 Hz, Approx. 100 VA
Dimensions and weight	Approx. 185 (H) x 155 (W) x 330 (D) mm, Approx. 7.5 kg

Not available in EU.



## PARTICLE COUNTERS LIQUID-BORNE

Compatible with a wide variety of fluids from pure water to hydrofluoric acid

Liquid-borne particles contamination have a significant effect on product quality.

In addition, fluids that are consumed by the human body are also thought to have an effect on human life depending on the properties of suspended particles.

The control of liquid-borne particles has become essential in all fields.

## Major fields of use of liquid-borne particle counters

Liquid-borne particle counters are used for the control of particles in chemical used for the semiconductor process specialized material such as SOG (spin on glass) and photoresist materials, ultrapure water and cleaning-use chemical agents (e.g., alkaline, organic solvents, hydrofluoric acid).

In addition, they are also used for the detection of coarse particles in chemical mechanical polishing (CMP) slurry, measurement methods include in-line and batch measurements.

## Management of chemical fluids

Chemical fluids are used in the precision electronic industry for cleaning as well as the removal of oxidized film and photo resist. Pure water and chemical fluids are used in large quantities especially in the production of semiconductors, hard disk drives (HDD) and flat panel displays (FPD). The control of liquid-borne particles has become essential for the realization of improvements in quality and yield due to the miniaturization and larger scale integration of such electronic devices.

In semiconductor production lines and spaces have now been reduced to less than 10 nm, while the head-to-media clearance in the production of HDD has dropped below 10 nm. In FPD production, there are demands for larger screens and higher quality for TVs and monitors, accordingly pixel defects on large glass substrate measuring 1 to 2 square meters cannot be permitted. It is thus important to control peripheral particles in order to ensure improvements in microfabrication technology and the production of high performance electronic devices. Liquid-borne particle counters play an important role as qualitative devices for measuring them.

## Cleaning process assessment and management

In semiconductor production, particles adhering to wafers are removed through a cleaning process. In addition, the generation of dust in the component parts themselves of products that require the suppression of dust, has a considerable impact on product quality and performance. It is therefore necessary to clean each of them individually and gauge the effect. In order to ensure highly effective and reliable cleaning, it is necessary to implement the management of various elements including the confirmation of particle count in the cleaning agent prior to use, volume of overflow in the cleaning agent tank, optimal supply volume of cleaning agent, optimal cleaning time and cleanliness of recycled cleaning agent. Particle measurement can be carried out effectively using liquid-borne particle counters as a means for clarifying the relationship between these various elements and throughput, yield, etc., and for resolving problem areas. Directly connecting a particle counter to supply-lines for cleaning tanks and recirculation lines as well as implementing constant monitoring makes it possible to identify particle fluctuations in cleaning tanks and recirculation lines and scientifically improve production lines.

### Pulse Height Analysis Software KF-50A

- Displays results of pulse height analysis as performed in particle counter
- Automatically calculates particle sizes from voltage values for display
- Suitable for noise check of samples with noise rise such as photoresist
- Ideal for maintenance purposes and for assuring particle counter classification accuracy
- Particle distribution data can be used to test particle generator stability

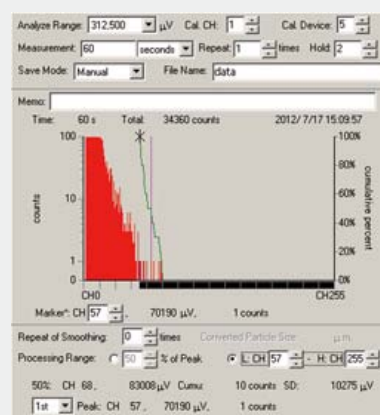

Pulse height analysis example

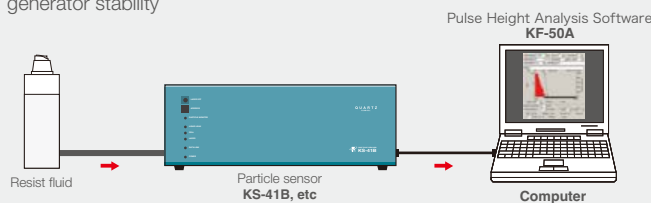

Standards for particle counters

[Light scattering liquid-borne particle counter]  
ISO 21501-2 (An extract)

Counting efficiency

The counting efficiency shall be  $(50 \pm 30) \%$  for calibration particles with a size close to the minimum detectable size, and it shall be  $(100 \pm 30) \%$  for calibration particles with the particle size of 1, 5 times to 3 times larger than the minimum detectable particle size.

False count rate

The false count rate is determined by measuring the particle number concentration in the unit of counts per litre at the minimum reported size range when sampling pure water.

Maximum particle number concentration

The maximum measurable particle number concentration shall be specified by the manufacturer. The coincidence loss at the maximum particle number concentration of an LSLPC shall be equal to or less than 10 %.

NOTE When the particle number concentration is higher than the maximum particle number concentration, the number of uncounted particles increases because of an enhanced probability of multiple particles existing in the sensing volume (coincidence error) and/or saturation of the electronic system.

Calibration interval

It is recommended that the calibration interval of an LSLPC be one year or less.

[Light extinction liquid-borne particle counter]  
ISO 21501-3 (An extract)

Counting efficiency

The counting efficiency shall be  $(100 \pm 20) \%$  when the test is carried out by the method described in 4.3.

Size resolution

The size resolution shall be equal to or less than 10 % when the test is carried out by the method described in 4.4.

Sampling volume

The standard uncertainty of sampling volume shall be equal to or less than  $\pm 5 \%$  of the preset value. This subclause does not apply when the LELPC is not equipped with a volumetric sampling system.

Maximum particle number concentration

The maximum measurable particle number concentration shall be specified by the manufacturer. The coincidence loss at the maximum particle number concentration of an LELPC shall be equal to or less than 10 %.

NOTE When the particle number concentration is higher than the maximum particle number concentration, the number of uncounted particles increases because of an enhanced probability of multiple particles existing in the sensing volume (coincidence error) and/or saturation of the electronic system.

Calibration interval

It is recommended that the calibration interval of an LELPC be one year or less.

Example of measurement with liquid-borne particle counters

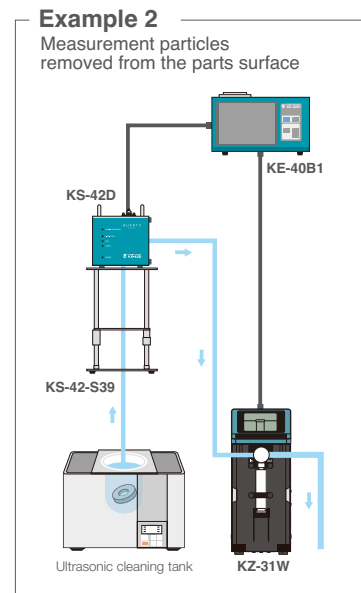
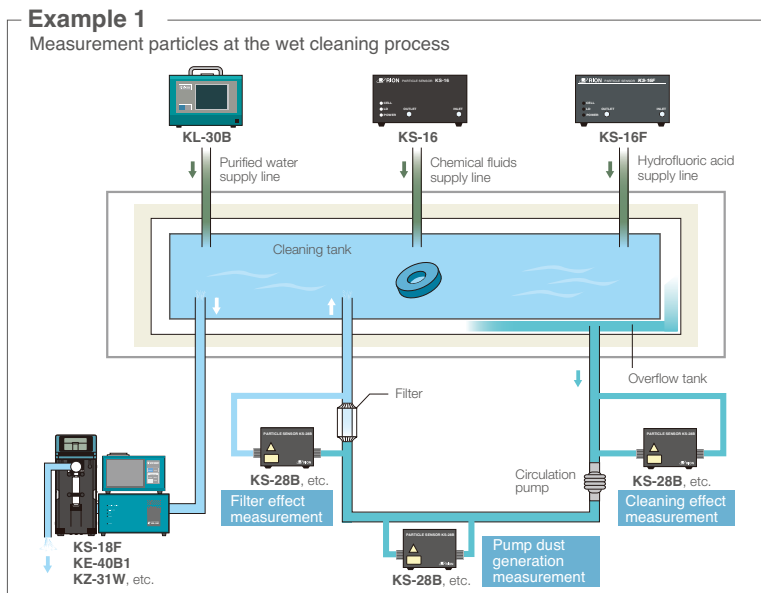

Example of application

Application	Target sample	Compatible models
Wet process	Acid (including HF), alkaline, organic solvents, pure water, etc.	KS-20F, KS-19F, KS-18F, KS-42A/42AF, KS-16/16F, KS-28B/28BF
Plant	Chemical fluids	KS-20F, KS-19F, KS-28B, KS-16/16F
	Pure water	KL-30A/30AX, KL-30B
Film formation	Insulating film material, film formation coating, etc.	KS-42A, KS-42B
Plating	Copper sulfate	KS-42B, KS-42C, KS-42D
Lithography	Resist, developing fluid, antireflection agents, etc.	KS-42B, KS-41A, KS-41B
Part dust generation test	Pure water, IPA	KS-42C
Injection fluid, cleanliness	Injection fluid, injection-use water, infusion solutions, rubber stoppers, etc.	KL-05



# PARTICLE COUNTERS LIQUID-BORNE



## Controller KE-40B1

Compatible connection models	KS-20F, KS-19F, KS-18F, KS-42A/42AF, KS-42B/42BF, KS-42C, KS-42D, KS-41A, KS-41B
Size range	10 channels
Numerical display	Count (max. 8 digits)
Measurement time	10 seconds to 2 hours, manual
Power	100 V to 240 V AC, 50/60 Hz, Approx. 130 VA
Dimensions and weight	Approx. 140 (H) × 240 (W) × 146 (D) mm, Approx. 3 kg



## Particle Sensor KS-41A (Light-scattering method)

For resist

Light source	Laser diode (wavelength 830 nm, rated output 200 mW)
Materials of parts exposed to sample	Synthetic quartz, PFA
Flow rate	10 mL/min
Setting range	0.15 $\mu\text{m}$ to 0.5 $\mu\text{m}$
Factory default (4 channels)	$\geq 0.15 \mu\text{m}$ , $\geq 0.2 \mu\text{m}$ , $\geq 0.3 \mu\text{m}$ , $\geq 0.5 \mu\text{m}$
Maximum particle number concentration	1 200 particles/mL (coincidence loss 5 %)
Power	DC12 V (Supplied by KE-40B1)
Dimensions and weight	Approx. 160 (H) × 300 (W) × 251 (D) mm, Approx. 7.5 kg



## Particle Sensor KS-41B (Light-scattering method)

For resist

Light source	Diode pumped solid state laser (wavelength 532 nm, rated output 500 mW)
Materials of parts exposed to sample	Synthetic quartz, PFA
Flow rate	5 mL/min
Setting range	0.1 $\mu\text{m}$ to 0.5 $\mu\text{m}$
Factory default (5 channels)	$\geq 0.1 \mu\text{m}$ , $\geq 0.15 \mu\text{m}$ , $\geq 0.2 \mu\text{m}$ , $\geq 0.3 \mu\text{m}$ , $\geq 0.5 \mu\text{m}$
Maximum particle number concentration	9 600 particles/mL (coincidence loss 10 %)
Power	DC12 V (supplied by KE-40B1)
Dimensions and weight	Approx. 164 (H) × 464 (W) × 305 (D) mm (excluding protruding parts), Approx. 12.5 kg

(Use of 10 mL glass syringe is necessary)



## Particle Sensor KS-20F (Light-scattering method)

Light source	Diode pumped solid state laser (wavelength 532 nm, rated output 1.5 W)
Materials of parts exposed to sample	Sapphire, PFA
Flow rate	10 mL/min
Setting range	0.02 $\mu\text{m}$ to 0.08 $\mu\text{m}$
Factory default (4 channels)	$\geq 0.02 \mu\text{m}$ , $\geq 0.03 \mu\text{m}$ , $\geq 0.04 \mu\text{m}$ , $\geq 0.06 \mu\text{m}$
Maximum particle number concentration	50 000 particles/mL (coincidence loss 10 %)
Power	100 to 240 V AC, 50/60 Hz, Approx. 250 VA
Dimensions and weight	Approx. 235 (H) $\times$ 552 (W) $\times$ 340 (D) mm, Approx. 18 kg



## Particle Sensor KS-19F (Light-scattering method)

Light source	Diode pumped solid state laser (wavelength 532 nm, rated output 800 mW)
Materials of parts exposed to sample	Sapphire, PFA
Flow rate	10 mL/min
Setting range	0.03 $\mu\text{m}$ to 0.13 $\mu\text{m}$
Factory default (4 channels)	$\geq 0.03 \mu\text{m}$ , $\geq 0.06 \mu\text{m}$ , $\geq 0.1 \mu\text{m}$ , $\geq 0.13 \mu\text{m}$
Maximum particle number concentration	40 000 particles/mL (coincidence loss 10 %)
Power	DC12 V (Supplied by KE-40B1)
Dimensions and weight	Approx. 170 (H) $\times$ 487 (W) $\times$ 310 (D) mm, Approx. 13.5 kg



## Particle Sensor KS-18F (Light-scattering method)

Light source	Diode pumped solid state laser (wavelength 532 nm, rated output 500 mW)
Materials of parts exposed to sample	Sapphire, PFA
Flow rate	10 mL/min
Setting range	0.05 $\mu\text{m}$ to 0.2 $\mu\text{m}$
Factory default (4 channels)	$\geq 0.05 \mu\text{m}$ , $\geq 0.1 \mu\text{m}$ , $\geq 0.15 \mu\text{m}$ , $\geq 0.2 \mu\text{m}$
Maximum particle number concentration	30 000 particles/mL (coincidence loss 10 %)
Power	DC12 V (supplied by KE-40B1)
Dimensions and weight	Approx. 147 (H) $\times$ 272 (W) $\times$ 442 (D) mm, Approx. 12 kg

# PARTICLE COUNTERS LIQUID-BORNE



## Particle Sensor

### KS-42A/42AF (Light-scattering method)

Light source	Laser diode (wavelength 830 nm, rated output 200 mW)
Materials of parts exposed to sample	KS-42A: Synthetic quartz, PFA KS-42AF: Sapphire, PFA
Flow rate	10 mL/min
Setting range	0.1 $\mu\text{m}$ and 0.13 $\mu\text{m}$ to 0.5 $\mu\text{m}$ Factory default (5 channels) $\geq 0.1 \mu\text{m}$ , $\geq 0.15 \mu\text{m}$ , $\geq 0.2 \mu\text{m}$ , $\geq 0.3 \mu\text{m}$ , $\geq 0.5 \mu\text{m}$ ( $\geq 1.0 \mu\text{m}$ support available as option)
Maximum particle number concentration	1 200 particles/mL (coincidence loss 5 %)
Power	DC12 V (Supplied by KE-40B1)
Dimensions and weight	Approx. 125 (H) $\times$ 240 (W) $\times$ 151 (D) mm, Approx. 4 kg

●KS-42AF: Compatible with hydrofluoric acid



## Particle Sensor

### KS-42B/42BF (Light-scattering method)

Light source	Laser diode (wavelength 780 nm, rated output 40 mW)
Materials of parts exposed to sample	KS-42B: Synthetic quartz, PFA, PTFE KS-42BF: Sapphire, PFA, PTFE
Flow rate	10 mL/min
Setting range	0.2 $\mu\text{m}$ to 2 $\mu\text{m}$ Factory default (5 channels) $\geq 0.2 \mu\text{m}$ , $\geq 0.3 \mu\text{m}$ , $\geq 0.5 \mu\text{m}$ , $\geq 1 \mu\text{m}$ , $\geq 2 \mu\text{m}$
Maximum particle number concentration	1 200 particles/mL (coincidence loss 5 %)
Power	DC12 V (Supplied by KE-40B1)
Dimensions and weight	Approx. 125 (H) $\times$ 240 (W) $\times$ 151 (D) mm, Approx. 3.2 kg

●KS-42BF: Compatible with hydrofluoric acid



## Particle Sensor

### KS-42C (Light-scattering method)

Light source	Laser diode (wavelength 780 nm, rated output 5 mW)
Materials of parts exposed to sample	Synthetic quartz, PFA, PTFE
Flow rate	10 mL/min
Setting range	0.5 $\mu\text{m}$ to 20 $\mu\text{m}$ Factory default (7 channels) $\geq 0.5 \mu\text{m}$ , $\geq 1 \mu\text{m}$ , $\geq 2 \mu\text{m}$ , $\geq 3 \mu\text{m}$ , $\geq 5 \mu\text{m}$ , $\geq 10 \mu\text{m}$ , $\geq 20 \mu\text{m}$
Maximum particle number concentration	1 200 particles/mL (coincidence loss 5 %)
Power	DC12 V (Supplied by KE-40B1)
Dimensions and weight	Approx. 125 (H) $\times$ 240 (W) $\times$ 151 (D) mm, Approx. 3 kg



## Particle Sensor KS-42D (Light obscuration method)

Light source	Laser diode (wavelength 780 nm, rated output 5 mW)
Materials of parts exposed to sample	Synthetic quartz, PFA, Perfluoro
Flow rate	25 mL/min
Setting range	2 $\mu\text{m}$ to 100 $\mu\text{m}$
Factory default (8 channels)	$\geq 2\ \mu\text{m}$ , $\geq 3\ \mu\text{m}$ , $\geq 5\ \mu\text{m}$ , $\geq 7\ \mu\text{m}$ , $\geq 25\ \mu\text{m}$ , $\geq 50\ \mu\text{m}$ , $\geq 100\ \mu\text{m}$ ( $\geq 150\ \mu\text{m}$ support available as option)
Maximum particle number concentration	10 000 particles/mL (coincidence loss 10 %)
Power	DC12 V (Supplied by KE-40B1)
Dimensions and weight	Approx. 125 (H) $\times$ 140 (W) $\times$ 150 (D) mm, Approx. 2.2 kg

●Sensor Stand KS-42-S39. option



Not available in EU.

## Particle Sensor KS-16/16F (Light-scattering method)

Light source	Laser diode (wavelength 830 nm, rated output 200 mW)
Materials of parts exposed to sample	KS-16: Synthetic quartz, PFA KS-16F: Sapphire, PFA
Flow rate	10 mL/min
Size range (5 channels)	$\geq 0.1\ \mu\text{m}$ , $\geq 0.15\ \mu\text{m}$ , $\geq 0.2\ \mu\text{m}$ , $\geq 0.3\ \mu\text{m}$ , $\geq 0.5\ \mu\text{m}$
Maximum particle number concentration	1 200 particles/mL (coincidence loss 5 %)
Power	100 V to 240 V AC, 40 VA (Including external power requirement KZ-50 (accessory))
Dimensions and weight	Approx. 110 (H) $\times$ 240 (W) $\times$ 150 (D) mm, Approx. 3.5 kg

●KS-16F: Compatible with hydrofluoric acid



Not available in EU.

## Particle Counter KL-28B/28BF (Light-scattering method)

Light source	Laser diode (wavelength 780 nm, rated output 40 mW)
Materials of parts exposed to sample	KS-28B: Synthetic quartz, PFA, PTFE KS-28BF: Sapphire, PFA, PTFE
Flow rate	10 mL/min
Size range (2 channels)	$\geq 0.2\ \mu\text{m}$ , $\geq 0.5\ \mu\text{m}$
Maximum particle number concentration	1 200 particles/mL (coincidence loss 5 %)
Power	Supplied by KE-28B, 100 V~240 V AC, 23 VA
Dimensions and weight	Approx. 70 (H) $\times$ 85 (W) $\times$ 118 (D) mm, Approx. 0.8 kg
Controller	KE-28B (exclusively for use with KS-28B/28BF)

●KS-28BF: Compatible with hydrofluoric acid

# PARTICLE COUNTERS LIQUID-BORNE



## Particle Counter

### KL-30AX (Light-scattering method)

For pure water

Printer supplied

Light source	Diode pumped solid state laser (wavelength 532 nm, rated output 500 mW)
Materials of parts exposed to sample	Synthetic quartz, fluorocarbon rubber, fluoroplastic, PVC, SUS304/316, Pyrex glass, POM
Sampling flow rate	Flow rate 20 mL/min and purge flow rate 0.1 to 1 L/min combined (Purge flow rate will differ depending on sample fluid pressure)
Setting range	0.04 $\mu\text{m}$ to 0.15 $\mu\text{m}$
Factory default (4 channels)	$\geq 0.04 \mu\text{m}$ , $\geq 0.08 \mu\text{m}$ , $\geq 0.1 \mu\text{m}$ , $\geq 0.15 \mu\text{m}$
Maximum particle number concentration	15 000 particles/mL (coincidence loss 10 %)
Power	100 V to 240 V AC, 50/60 Hz 130 VA
Dimensions and weight	Approx. 230 (H) $\times$ 385 (W) $\times$ 570 (D) mm, Approx. 24.8 kg



## Particle Counter

### KL-30A (Light-scattering method)

For pure water

Printer supplied

Light source	Diode pumped solid state laser (wavelength 532 nm, rated output 500 mW)
Materials of parts exposed to sample	Synthetic quartz, fluorocarbon rubber, fluoroplastic, PVC, SUS304/316, Pyrex glass, POM
Sampling flow rate	Flow rate 20mL/min and purge flow rate 0.1 to 1L/min combined (Purge flow rate will differ depending on sample fluid pressure)
Setting range	0.05 $\mu\text{m}$ to 0.2 $\mu\text{m}$
Factory default (4 channels)	$\geq 0.05 \mu\text{m}$ , $\geq 0.1 \mu\text{m}$ , $\geq 0.15 \mu\text{m}$ , $\geq 0.2 \mu\text{m}$
Maximum particle number concentration	15 000 particles/mL (coincidence loss 10 %)
Power	100 V to 240 V AC, 50/60 Hz 130 VA
Dimensions and weight	Approx. 230 (H) $\times$ 385 (W) $\times$ 570 (D) mm, Approx. 24.8 kg



## Particle Counter

### KL-30B (Light-scattering method)

For pure water

Printer supplied

Light source	Laser diode (wavelength 830 nm, rated output 200 mW)
Materials of parts exposed to sample	Synthetic quartz, fluorocarbon rubber, fluoroplastic, PVC, SUS304/316, Pyrex glass, POM
Sampling flow rate	Flow rate 10 mL/min and purge flow rate 0.1 to 1 L/min combined (Purge flow rate will differ depending on sample fluid pressure)
Setting range	0.05 $\mu\text{m}$ to 0.2 $\mu\text{m}$
Factory default (4 channels)	$\geq 0.05 \mu\text{m}$ , $\geq 0.10 \mu\text{m}$ , $\geq 0.15 \mu\text{m}$ , $\geq 0.20 \mu\text{m}$
Maximum particle number concentration	200 000 particles/mL (coincidence loss 10 %)
Power	100 V to 240 V AC, 50/60 Hz, Approx. 80 VA
Dimensions and weight	Approx. 230 (H) $\times$ 330 (W) $\times$ 569 (D) mm, Approx. 19.8 kg

# PARTICLE COUNTERS GAS-BORNE

## Direct measurement of material gases for semiconductor production

Many material gases that are toxic, flammable, corrosive or reactive are used in production processes for semiconductors, FPDs, solar cells and other products. Such gases may react, for example, with moisture and readily produce particulate matter. It is necessary to conduct measurements safely with no leakage while controlling such reactions in order to inhibit particle contamination in the material gases.

The KS-93 gas-borne particle counter incorporates a flow path unit using a flow cell in the particle detection unit, realizing leakage of less than  $1 \times 10^{-10} \text{Pa.m}^3/\text{s}$  (vacuum hood method) and the case also has a hermetically sealed structure of less than  $1 \times 10^{-6} \text{Pa.m}^3/\text{s}$  (sniffer method) as a safeguard against accidents. The flow path consists of SUS316 tubing and a quartz flow cell and is readily capable of purging by straight tube connection with no dead space.

Example of dust generation measurement in the material gas supply system

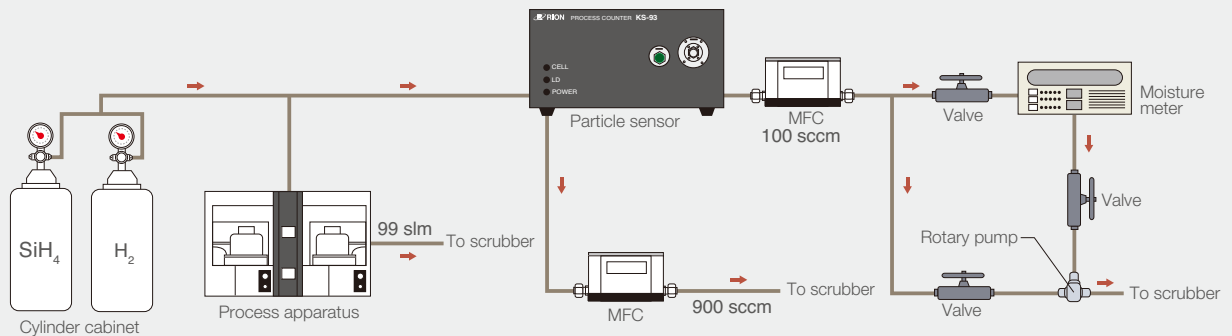

Example of particle dust generation measurement in gas cylinders

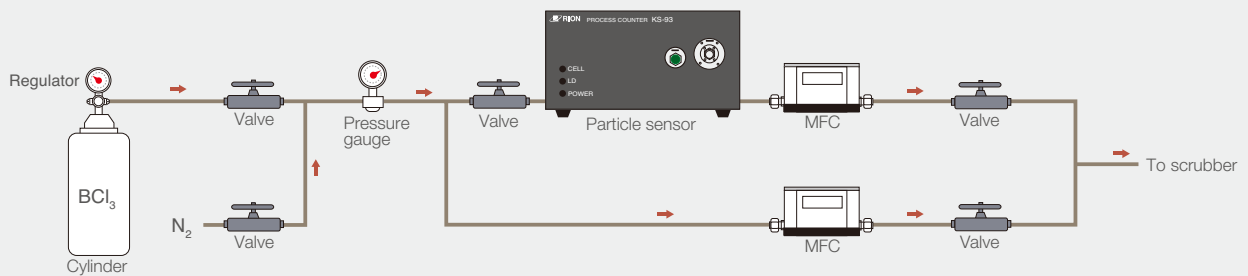

Not available in EU.

## Particle Sensor KS-93 (Light-scattering method)

Light source	Laser diode (wavelength 830 nm, rated output 200 mW)
Materials of parts exposed to sample gas	Synthetic quartz, SUS316 L, Fluorocarbon rubber
Flow rate	100 mL/min
Size range (5 channels)	$\geq 0.1 \mu\text{m}$ , $\geq 0.15 \mu\text{m}$ , $\geq 0.2 \mu\text{m}$ , $\geq 0.3 \mu\text{m}$ , $\geq 0.5 \mu\text{m}$
Maximum particle number concentration	30 000 particles/min (coincidence loss 5 %)
Power	100 V to 240 V AC, 40 VA (including external power requirement KZ-50 (accessory))
Dimensions and weight	Approx. 135 (H) × 280 (W) × 150 (D) mm, Approx. 6.5 kg (Build to order)

PARTICLE COUNTERS

# MONITORING SYSTEM

## Multi-point Monitoring Systems

Example of clean room environment management

Simultaneous monitoring of particle count, pressure, humidity, temperature, vibration, etc.

Example in process management

1. Application to chemical fluid supply systems with centralized management of multiple types of chemical fluids
2. Air control of the filling module in the PET bottle beverage filling process and air control in the cap mounting module; environment and water management
3. Constant monitoring of mini-environment wafer handling area (FIMS) and a broad range of other uses

## Sensor multi-point monitoring systems

Installation of sensors at the various measurement points; simultaneous measurement at all measurement points

- Measurement is possible on the same cycle even if measurement points are increased.
- General particle concentration changes can be ascertained through continuous measurement.

## Examples of multi-point monitoring installation

AP Airborne particle counter LP Liquid-borne particle counter TH Thermo-hygrometer p Differential pressure gauge

### Semiconductor

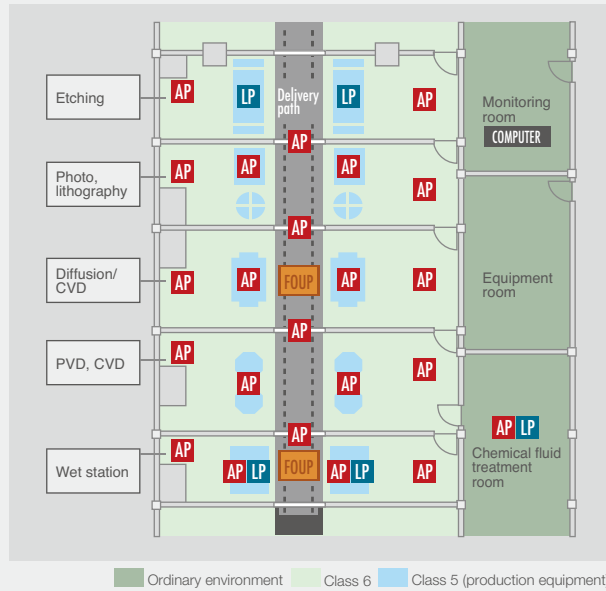

### Bio-clean room

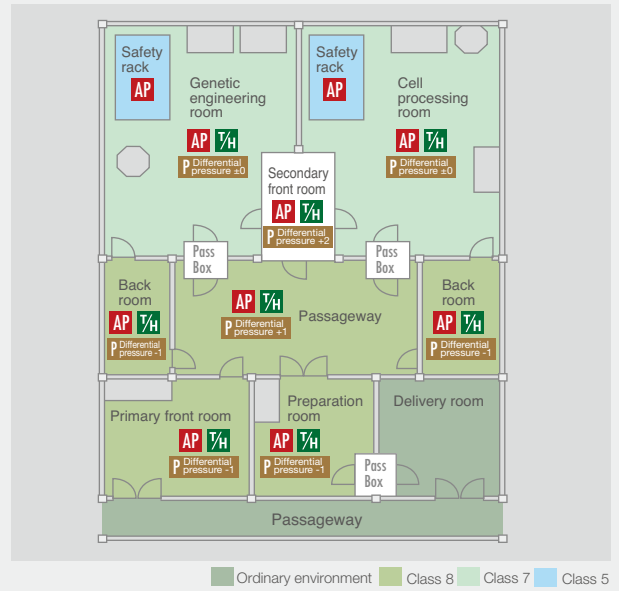

### Vehicle production plant

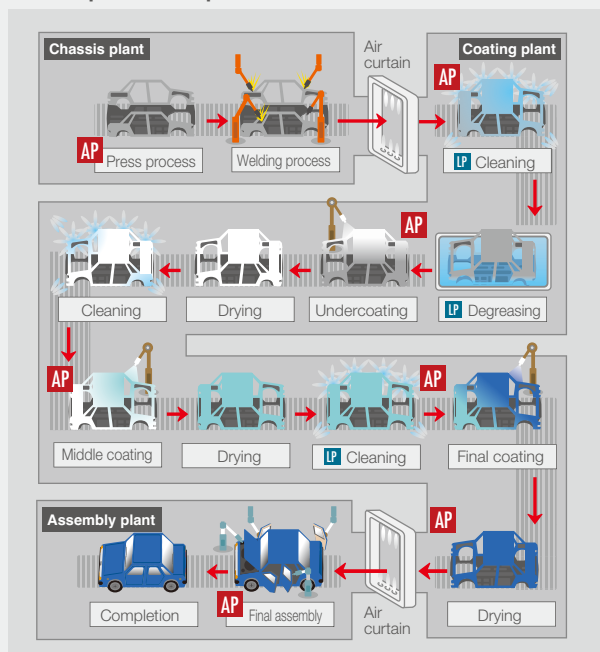

## Tube multi-point monitoring systems

Tubing is distributed from a single counter and measurements are made while switching from one measurement point to the next in succession.

- The system can be set up at lower cost than sensor multi-point systems.
- Easy installation in pasteurization zones.

Example of the tube multi-point monitoring system configuration

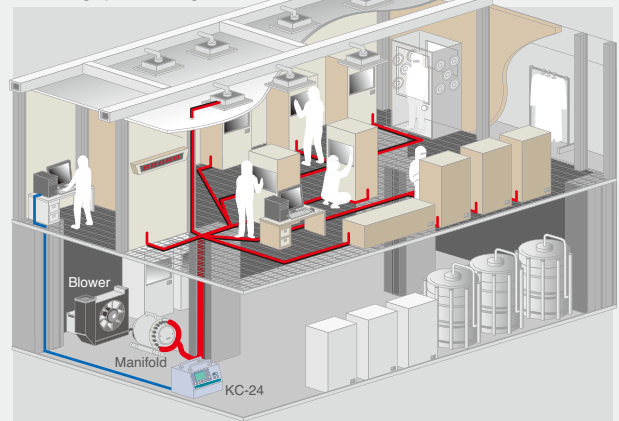

## Software

## RP Monitor Evo10 K1701 Ver. 2 / Evo10 K1701P Ver. 2 (Conforms to 21CFR Part11)

## Compatible models

- KC-01E, KC-03B, KC-20A, KC-24, KC-52A, KC-31/32, KC-22A/22B, KE-40B1, KL-28B/28BF, KS-16/16F, KL-30A/30AX/30B

- Allows control of particle counter measurement start/stop, and light source/internal pump on/off
- Available setting parameters include measurement time, period, number of measurements, alarm, conversion etc.
- Comments can be entered (at the beginning of a measurement or in a history graph)
- Display mode selection allows real-time numeric indication on another computer, separate from the control computer

Allows control of up to 8 particle counters in serial mode, using 8 ports

- Supported OS:  
Microsoft Windows 10 Pro 64 bit / 11 Pro 64 bit (English, Japanese)
- Data storage format:  
Binary file format (Conversion to text file (CSV) is also possible)

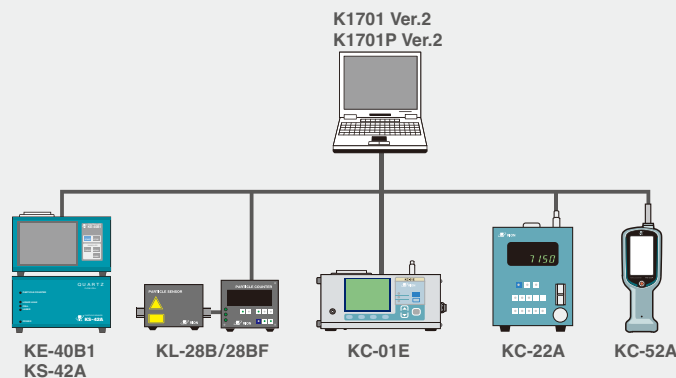

## RP Monitor Evo10 K1701 Ver. 3 / Evo10 K1701P Ver. 3 (Conforms to 21CFR Part11)

## Compatible models

- KA-02, KA-03, KA-05, KA-82, KC-31M, KC-24, KC-52A, KC-01E, KC-03B, KC-20A, KC-31/32, KC-22A/22B, KE-40B1, KL-28B/28BF, KS-16/16F, KL-30A/30AX/30B

- Allows control of particle counter measurement start/stop, and light source/internal pump on/off
- Available setting parameters include measurement time, period, number of measurements, alarm, conversion etc.
- Comments can be entered (at the beginning of a measurement)
- Display mode selection allows real-time numeric indication on another computer, separate from the control computer

Allows simultaneous control of up to 31 particle counters in serial mode and multi mode R (expanded connection up to 160 units)

## Peripheral device models

Automatic alarm mail delivery system K1906, particle count and alarm status indicator (display unit), digital temperature/humidity sensor K1813, signal tower

- Supported OS:  
Microsoft Windows 10 Pro 64 bit / 11 Pro 64 bit (English, Japanese)
- Data storage format:  
Binary file format (Conversion to text file (CSV) is also possible)

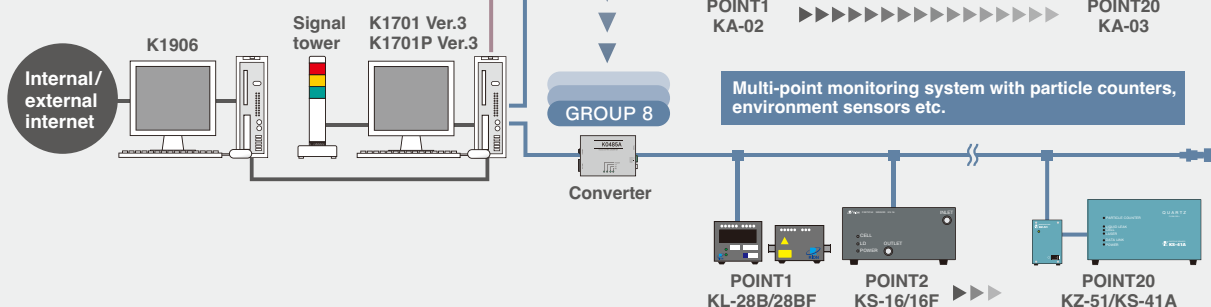



## PARTICLE COUNTERS

# PHARMACEUTICAL PRODUCTS

## Injection Management

Since injections are injected directly into human bodies, the number and size of the insoluble particles are stipulated in pharmacopoeia. Due in part to the fact that, unlike the electronic industry, it is not possible in the pharmaceutical industry to confirm the occurrence of defects in the plant and, in the worst case, the outcome could affect patient's life. Therefore it is necessary to be able to scientifically prove that there are only target ingredients and no insoluble particles, microorganisms and other impurities with production and inspection of the injection.

The Japanese pharmacopoeia strictly specifies the specification of the light obscuration automatic particle counters to be used to measure insoluble particles. Some specifications are measuring method, standard particles to be used, particle size accuracy, particle resolution, sample volume and counting efficiency.

As an option, light obscuration particle counter KL-05 can be customized to conform to Japanese Pharmacopoeia, United States Pharmacopoeia, European Pharmacopoeia, Korean Pharmacopoeia and Chinese Pharmacopoeia. Sensor, controller, sampler and display are made in to one unit to save the space and mobility. Measurement data is recorded automatically to the unit and it also has function to decide "pass" or "fail" against required quality. This data can also be sent to LIMS (Laboratory Information Management System) or converted to PDF file.

It has a digital signature, audit trail functions which complies to the guide line "21 CFR Part 11" of the FDA (Food and Drug Administration)

If there is a need to have sensor, controller and syringe sampler as separate apparatus, it is possible by using KS-42D (Sensor), KE-40B1 (Controller) and KZ-31W (Syringe sampler). One pharmacopoeia can be supported as an option.

### Criteria for JP, USP, EP, KP and ChP Insoluble Particulate Matter Tests

		JP/KP/ChP	USP/EP
Large volume	10 µm or more	No more than 25 particles/mL (100 mL or more)	No more than 25 particles/mL (over 100 mL)
	25 µm or more	No more than 3 particles/mL (100 mL or more)	No more than 3 particles/mL (over 100 mL)
Small volume	10 µm or more	No more than 6 000 particles/container (Less than 100 mL)	No more than 6 000 particles/container (100 mL or less)
	25 µm or more	No more than 600 particles/container (Less than 100 mL)	No more than 600 particles/container (100 mL or less)

JCC-54 added to the KL-05 enables you to measure samples during pressurization.

## Compressing chamber JCC-54



Supported types of sample fluid	Fluids where the fluid or its gases will not corrode the materials of the unit
Chamber pressure (inside)	50 kPa
Materials of parts exposed to sample	PTFE, PAF, PP, FKM (Fluoro rubber)
Dimension, weight	340 (H) × 245 (W) × 245 (D) mm, Approx. 12 kg (Excluding pump) <small>(Custom-made product)</small>



## Light obscuration Particle Counter

# KL-05 Conforms to 21CFR Part 11 (Light obscuration method)

Light source	Laser diode (wavelength 790 nm, rated output 4.5 mW)
Fluid-contacting materials	Flow cell: Synthetic quartz Syringe: Borosilicate glass, PTFE Syringe pump: Kel-F (PCTFE), PTFE Tube, packing, joint: PFA, PTFE, PCTFE, Perflo (special fluorine rubber) Sample container plate: Polyacetal
Measurable particle size range	1 to 20 ranges from 1.3 µm to 100 µm (in 0.1 µm steps)
Flow rate	25 mL/min
Maximum particle number concentration	10 000 particles/mL (coincidence loss 10 %)
Power	100 V to 240 V AC, 50/60 Hz, approx. 80 VA
Dimensions and weight	Approx. 366 (H) × 360 (W) × 236 (D) mm (excluding protruding parts), Approx. 10 kg

# PARTICLE COUNTERS VALIDATION

We support validation operations.

## What is validation?

In order to obtain the quality that is expected of a product, it is necessary to scientifically verify that the inspection and analysis methods, operational processes, etc., are appropriate and to document and file that in the form of a record. In GMP (Good Manufacturing Practice), validation is defined as the “development of a system capable of constantly verifying product safety and effectiveness based on scientific grounds” with the objective of “ensuring quality in the production of pharmaceuticals, etc.” We support validation operations (IQ, OQ, PQ) of the particle counters or multi-point monitoring systems that you use.

## RION validation service operations

### Installation Qualification (IQ): Evaluation of qualifications at the time of installation

- Confirmation of delivered items
- Check of external appearance of delivered products
- Confirmation of initial conditions
- Preparation of a record of confirmation items

### Operation Qualification (OQ): Evaluation of qualifications at the time of operation

- Confirmation of operating conditions
- Confirmation that the action and function of the delivered products conform with specifications, etc.
- Preparation of a record of confirmation items

### Performance Qualification (PQ): Performance qualification evaluation

- Performance confirmation tests at the time of actual operation
- Preparation of a record of confirmation items

## Operational flow

1

Discussion with customers  
(Confirmation of IQ, OQ and PQ)



2

Preparation and approval of IQ, OQ and PQ implementation plans



3

Implementation of IQ, OQ and PQ operations

- Required documents
- Traceability system diagrams
  - Test results reports
  - Instruction manuals
  - Calibration certificates
  - Specification sheets



4

Preparation of IQ, OQ and PQ implementation records



# PARTICLE COUNTERS OPTION



## Printer KP-06A

Particle size ranges	Maximum 6 ranges (depending on particle counter)
Measuring results	Date / time, Count for each size range
printout items	(total only, or single and total values)
Repeated measurement	1 time to 99 times
Usable paper type	TP-08 Thermosensitive paper TP-10 Lint-free thermosensitive paper
Power	100 V to 240 V AC, 50/60 Hz, Approx. 20 VA
Dimensions and weight	Approx. 66 (H) x 170 (W) x 242 (D) mm (without protruding parts), Approx. 2.5 kg

\*Interface cable CC-61A (Option)



## Thermal Printer DPU-S245

(For KC-51/52A)  
(This Printer is products of Seiko Instruments Inc.)

Printing method	Thermal line dot printing
Print digit count	32 digits
Printer paper	TP-34 Thermosensitive paper TP-33 Lint-free thermosensitive paper
Power	AC adaptor, Li-Ion Rechargeable battery
Dimensions and weight	Approx. 45 (H) x 83 (W) x 130 (D) mm, Approx. 280 g



## Syringe Sampler KZ-31W

Suitable syringe sizes	25 mL
Operation mode (Repeat count setting range)	Purge mode (50), Measurement mode (50), Combination mode (20)
Setting range	5 to 100 mL/min (with liquid-borne particle counter connected)
Power	100 to 240 V AC, approx. 50 VA
Dimensions and weight	Approx. 345 (H) x 141 (W) x 215 (D) mm, Approx. 5.5 kg



## Bellows Sampler K9904B/D

Maximum discharge volume	15 mL/stroke
External pressure	200 kPa
Fluid viscosity	30 mPa · s (with 10 mL/min)
Power	100 V to 240 V AC, Approx. 50 VA
Dimensions and weight	Approx. 106 (H) x 230 (W) x 150 (D) mm, Approx. 2 kg



## Mass Flow Controller CVR-1/4-FM (Viton) CVR-1/4-P-FM (Perfluor)

(This Mass Flow Controller is products of Surpass Industry Co.,Ltd.)

Allowable sample type	Pure water, chemical fluids
Flow	10 to 31.2 mL/min
Pressure used	100 kPa to 400 kPa
Dimensions and weight	Approx. 125 (H) x 185 (W) x 110 (D) mm, Approx. 2.4 kg



## Aerosol Dilution System XP-M8A/M8B

Connectable particle counters	KC-22B (XP-M8A), KC-01E (XP-M8B)
Dilution ratio	20, 40, 60, 80, 100 times
Dilution accuracy	±30 % (Dilution ratio 100 times at particle size 0.5 μm or less)
Power	100 V to 240 V AC ±10 %, 50/60 Hz
Dimensions and weight	Main unit: Approx. 215(H)×200(W)×280(D)mm(excluding projections), XP-M8A: Approx. 5.4 kg / XP-M8B: Approx. 6.9 kg

(Build to order)



## Sampler KZ-30U (with pressure control unit)

Supported types of sample fluid	Fluids where the fluid or its gases will not corrode the materials of the unit
Pressure adjustment range	0.02 to 0.2 Mpa (gauge pressure)
Materials of parts exposed to sample	PFA, PTFE, CTFE
Dimensions and weight	Approx. 690 (H) x 250 (W) x 400 (D) mm, Approx. 19 kg

\*External pump KZ-28M option

Particles with outstanding diameter  
precision and distribution  
Particle size precision is  
±3 % of the displayed value

## CLINTEX (standard particle concentration)

Type	Particle size	Guaranteed particle concentration
CTX03420	0.34 μm	1 000 particles/mL±10 %
CTX06020	0.60 μm	1 000 particles/mL±10 %
CTX21120	2.09 μm	1 000 particles/mL±10 %
CTX10410	10.14 μm	1 000 particles/mL±10 %



(Build to order)



Rion was founded in 1944 to develop and commercialize products based on research at Kobayashi Institute of Physical Research, a foundation dedicated to the study of physics and acoustics. Rion has three business divisions: “the Medical Instrument Division”, “the Environmental Instrument Division”, and “the Particle Counter Division”. The Medical Instrument Division develops, manufactures, and sells hearing instruments, assistive devices, and medical equipment, mainly used in the field of otolaryngology (ear, nose and throat). “The Environmental Instrument Division” develops, manufactures, and sells sound and vibration measuring instruments, including sound level meters, vibration meters and seismometers. “The Particle Counter Division” develops, manufactures, and sells particle counters to measure particles in the air and liquids. We plan to continue to supply products to meet the needs of our customers, maintain our position as a leading company in the industry, and further develop products for use worldwide. We aim to promote people’s health and welfare, and to create a safe and comfortable environment based on our corporate philosophy of “Helping people, society, and the world through all our actions.”

## RION Product Sectors

### Particle Counters

- Airborne particle counters
- Liquid-borne particle counters
- Gas-borne particle counters
- Multi-point monitoring system

### Sound and vibration measuring instruments

- Sound level meters
- Vibration meters
- Frequency analyzers
- Recorders

### Hearing instruments

- In-the-ear type
- Behind-the-ear type
- Body-worn type

### Medical to equipment

- Audio meters
- Audiometric test booth
- Hearing aid tester
- Vibrotactile perception meter

## Particle Counter Traceability System

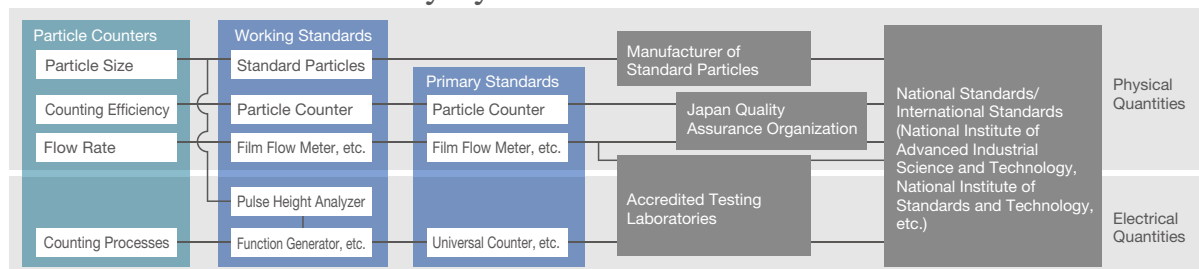

## RION Service centers

### North & South America / Europe / Middle East MGN INTERNATIONAL Inc.

Tel: +1-951-719-2910 Fax: +1-951-719-2920  
Address: 41665 Date St., Suite 100A Murrieta, CA 92562, U.S.A.  
URL: <https://mgintl.com/>

### Europe PMT Partikel-Messtechnik GmbH

Tel: +49-7033-5374-30 Fax: +49-7033-5374-22  
Address: Schafwäsche 8 71296 Heimsheim Germany  
URL: <https://www.pmt.eu>

### China Shanghai Amity Technology CO., LTD.

Tel: +86-21-5811-1093 Fax: +86-21-5811-0953  
Address: Fl.7, No.5, Wenyi Rd., Huinan Town, Pudong New Area, Shanghai, China

### Taiwan Taiwan Amity Technology CO., LTD.

Tel: +886-3-658-7293 Fax: +886-3-658-7256  
Address: Rm.1, Fl.21, No.8, Zihciang S. Rd., Chu-Pei City, Hsinchu County 30264, Taiwan  
URL: <https://www.twamity.com.tw/>

### Korea CHARM TECHNOLOGY CO., LTD.

Tel: +82-2-711-0694/5 Fax: +82-2-711-0706  
Address: (GiDC Gwangmyeong) C-903, 43 Iljik-ro, Gwangmyeong-si, Gyeonggi-do, 14353, Korea  
URL: <http://www.charmtechnology.co.kr>

### Philippines NAGASE PHILIPPINES INTERNATIONAL SERVICES CORPORATION

Tel: +63-2-750-2935 Fax: +63-2-625-0085  
Address: 12th Floor, Salcedo Towers, 169 H. V. Dela Costa Street, Salcedo Village, Makati City, Philippines 1227  
URL: <https://www.nagase.co.jp/english/>

### Singapore NAGASE SINGAPORE (PTE) LTD. Machinery Service Centre

Tel: +65-6686-2518 / +65-6686-2538 Fax: +65-6686-3391  
Address: Block 18, TradeHub 21, #07-139, Boon Lay Way, Singapore 609966  
URL: <https://www.nagase.co.jp/english/>

### Thailand NAGASE (THAILAND) CO., LTD.

Tel: +66-2-825-7000 Fax: +66-2-825-7111  
Address: 14th Floor, Ramaland Building, 952 Rama IV Rd., Suriyawongse, Bangrak, Bangkok, Thailand 10500  
URL: <https://www.nagase.co.jp/english/>



All products that have particle detection modules use lasers. The laser product class is : class 1, IEC 60825-1

\* Company names and product names mentioned in this catalog are usually trademarks or registered trademarks of their respective owners.  
\* Specifications subject to change without notice.

Distributed by:

 **RION CO., LTD.**  
<https://www.rion.co.jp/english/>

3-20-41, Higashimotomachi, Kokubunji,  
Tokyo 185-8533, Japan  
Tel: +81-42-359-7878, Fax: +81-42-359-7445